

NEC digital cinema projectors

XDC 3000NL

Digital Xenon Cinema N-type lamps are ideal for today's demanding 3D and 2D digital cinema presentations. They are especially designed for NEC projectors. There is a choice of three power ratings in the N-type Digital Cinema Xenon lamps range: 4000W, 4500W or 6000W. There is also a choice of three power ratings in the NH-type Digital Helios lamps range: 2000W, 300W, and 4200W. All these lamps produce the very high light output needed to maximize screen brightness and enhance the dramatic effect for the viewer. These long-life digital lamps also provide constant color temperature characteristics, and meet all of the stringent arc-stability requirements for consistent customer satisfaction. In addition to N-type Digital Cinema Xenon lamps there are B-, C-, S-, and TA-type Digital Cinema Xenon lamps. These are all individually customized per projector, so there is a different, perfect-fitting lamp for each projector model to ensure optimized projector performance.

Product data

General Information	
Operating Position	P5 [Parallel +/-5D or Horizontal(HOR)]
Main Application	Cinema
Nominal Lifetime (Nom)	1700 h
Magnet	-
Operating and Electrical	
Power (Rated) (Nom)	3000 W
Lamp Current Span	45-110 A
Lamp Current (Nom)	100 A
Voltage (Nom)	30 V

Product Data	
Full product code	871869659421600
Order product name	XDC 3000NL
EAN/UPC - Product	8718696594216
Order code	928419606301
Numerator - Quantity Per Pack	1
Numerator - Packs per outer box	1
Material Nr. (12NC)	928419606301
Net Weight (Piece)	595.000 g

NEC digital cinema projectors

Dimensional drawing

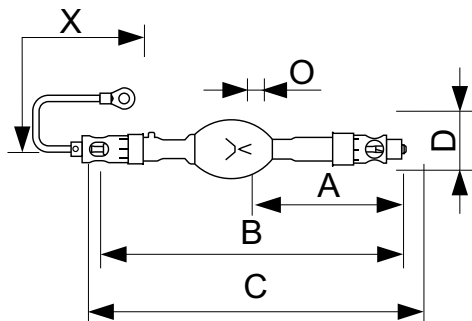

Product	O	D	X	B	C	A
XDC 3000NL	5.5 mm	60 mm	306 mm	306 mm	336 mm	144 mm

XDC-3000NL

