



Barco digital cinema projectors

XDC 6500 B

Digital Xenon Cinema B-type lamps are ideal for today's demanding 3D and 2D digital cinema presentations. They are especially designed for Barco projectors. There is a choice of three power ratings in the B-type Digital Xenon Cinema lamps range: 3000W, 4000W, or 6500W. There is also a choice of three power ratings in the BH-type Digital Helios lamps: 2000W, 3000W, and 4200W power ratings. All these lamps produce the very high light output needed to maximize screen brightness and enhance the dramatic effect for the viewer. These long-life digital lamps also provide constant color temperature characteristics, and meet all of the stringent arc-stability requirements for consistent customer satisfaction. In addition to B-type Digital Cinema Xenon lamps there are C-, N-, S-, and TA-type Digital Cinema Xenon lamps. These are all individually customized per projector, so there is a different, perfect-fitting lamp for each projector model to ensure optimized projector performance.

Product data

General Information	
Operating Position	P15 [Parallel +/-15D or Horizontal(HOR)]
Main Application	Cinema
Nominal Lifetime (Nom)	500 h
Magnet	Horizontal required

Operating and Electrical	
Power (Rated) (Nom)	6500 W
Lamp Current Span	140/175 A
Lamp Current (Nom)	170 A
Voltage (Nom)	38 V

Product Data	
Full product code	872790085636100
Order product name	XDC 6500 B
EAN/UPC - Product	8727900856361
Order code	928415006301
Numerator - Quantity Per Pack	1
Numerator - Packs per outer box	1
Material Nr. (12NC)	928415006301
Net Weight (Piece)	1.165 kg

Barco digital cinema projectors

Dimensional drawing

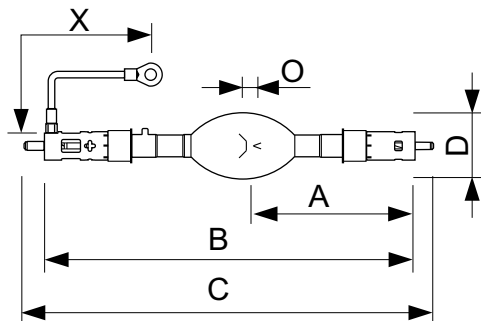

Product	O	D	X	B	C	A
XDC 6500 B	7.5 mm	70 mm	152 mm	391 mm	433 mm	170.5 mm

LTIX XDC 6500W B

